

Serbelloni

Design:

VICO MAGISTRETTI
CENTRO DESIGN BINFARÉ



+ info: <https://www.depadova.com/materials.pdf>

De Padova srl - info@depadova.it

UPHOLSTERED EXECUTIVE CHAIR

Materials

Frame
steel with elastic straps.

Base
polished chrome-plated or matt black powder-coated steel. Pneumatic height-adjustment and self-stabilizing mechanism. Swivel thermoplastic castors with safety brake.

Padding
variable-density polyurethane foam and polyester wadding covered with light polyester velvet. For the FR (Fire Resistant) versions on request, the filling materials comply with the current regulations.

Exterior shell
full grain, vegetable- tanned and aniline-dyed cowhide.

Cover
interior cover (seat cushion and back) in leather or fabric, totally removable with zipper. Zip edge with cotton or leather tape.

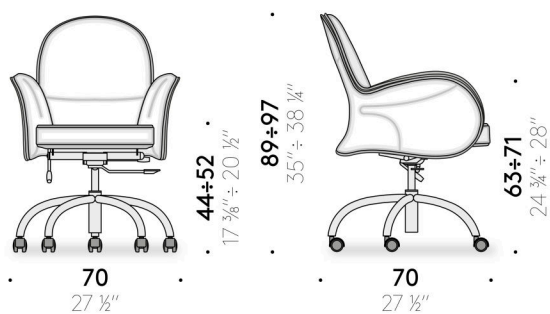

Serbelloni

Design:

VICO MAGISTRETTI
CENTRO DESIGN BINFARÉ



+ info: <https://www.depadova.com/materials.pdf>

De Padova srl - info@depadova.it

SEDIA DIREZIONALE IMBOTTITA

Materiali

Struttura

acciaio con cinghie elastiche.

Basamento

acciaio cromato lucido o verniciato a polvere color nero opaco. Pistone a gas per regolazione in altezza e meccanismo basculante. Ruote piroettanti in materiale termoplastico con freno di sicurezza.

Imbottitura

poliuretano espanso a quote differenziate e ovatta di poliestere foderato con vellutino di poliestere. Per le versioni FR (Fire Resistant) a richiesta, i materiali dell'imbottitura sono come da normative.

Scocca esterna

cuoio pieno fiore conciato al vegetale e tinto all'anilina.

Rivestimento

rivestimento interno in pelle o in tessuto completamente sfoderabile tramite cerniera zip. Bordo della cerniera in fettuccia di cotone o di pelle.

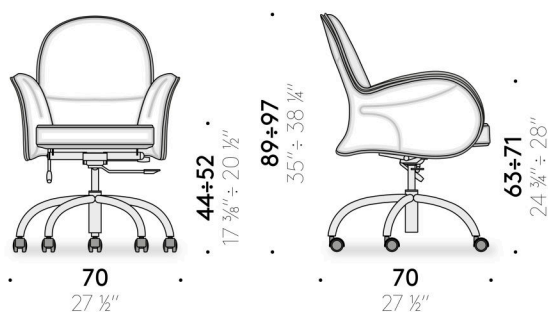

Serbelloni

Design:

VICO MAGISTRETTI
CENTRO DESIGN BINFARÉ



+ info: <https://www.depadova.com/materials.pdf>

De Padova srl - info@depadova.it

CHAISE DE DIRECTION REMBOURRÉE

Matériaux

Structure

acier avec sangles élastiques.

Embase

acier chromé poli ou peint à poudre couleur noir mat. Piston à gaz pour réglage en hauteur et mécanisme basculant. Roulettes pivotantes en thermoplastique avec frein de sécurité.

Rembourrage

mousse de polyuréthane à densité variable et ouate de polyester doublée en velours de polyester. Pour les versions FR (Fire Resistant) sur demande, les matériaux du rembourrage sont conformes aux réglementations.

Coque externe

cuir pleine fleur tanné au végétal et teinté à l'aniline.

Revêtement

revêtement interne en cuir ou en tissu complètement déhoussable à l'aide de fermeture à glissière zip. Bord de la glissière en ruban de coton ou de cuir.

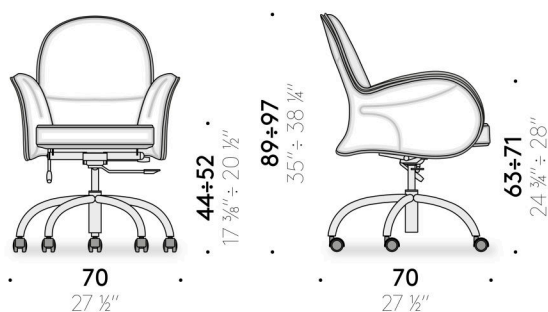

Design:

VICO MAGISTRETTI
CENTRO DESIGN BINFARÉ



+ info: <https://www.depadova.com/materials.pdf>

De Padova srl - info@depadova.it

GEPOLSTERTER CHEF-STUHL

Materialien

Gestell
Stahl mit elastischen Gurten.

Untergestell

Verchromter polierter Stahl oder mit Pulverlackierung, mattschwarz gefärbt.
Mit Höhengasdruckfeder sowie Kippmechanik. Lenkrollen aus thermoplastischem Material mit Sicherheitsbremse.

Polsterung

Polyurethanschaum unterschiedlicher Dichte und Polyesterwatte, mit Überzug aus Polyestersamt. Bei den FR-Versionen (Fire Resistant), die auf Anfrage erhältlich sind, entsprechen die Polstermaterialien den geltenden Bestimmungen.

Äußere Sitzschale

aus pflanzlich gegerbtem vollnarbigem und anilingefärbtem Kernleder.

Bezug

Innenbezug (für Sitzkissen und Rückenlehne) in Leder oder Stoff, abnehmbar mit Reißverschluss. Baumwoll- oder Lederpaspel.

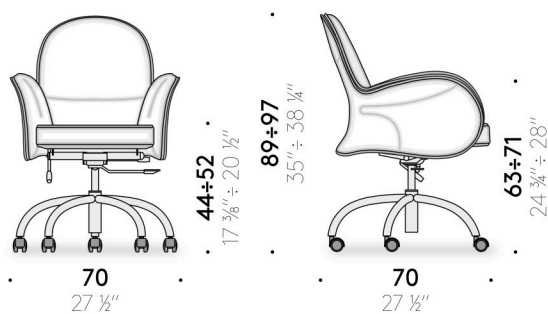

Serbelloni

Design:

VICO MAGISTRETTI
CENTRO DESIGN BINFARÉ



+ info: <https://www.depadova.com/materials.pdf>

De Padova srl - info@depadova.it

SILLA DIRECCIONAL TAPIZADA

Materiales

Estructura

acero con cinchas elásticas.

Base

acero cromado brillante o lacado en polvo color negro mate. Piston de gas para regulación en altura y mecanismo basculante. Ruedas giratorias en material termoplastico con freno de seguridad.

Relleno

espuma de poliuretano de densidad diferente y guata de poliéster tapizadas con terciopelo de poliéster. Para las versiones FR (Fire Resistant) bajo pedido, los materiales del relleno cumplen con las normativas.

Bastidor exterior

cuero plena flor curtido al vegetal y teñido a la anilina.

Revestimiento

revestimiento en piel o tejido completamente desfundable a través de cremallera. Borde de la cremallera con cinta de algodón o de piel.

